



“Monitoring and Advanced Control for Large Scale Ethanol Plant – Issues and Perspectives”

**AUTOMATIZED PLANTS AND
INTELLIGENT BUSINESS MANAGEMENT ORIENTED**

**CHRISTIAN ROBSON MARCATTO – SIEMENS
LOURDES ANDREO GONÇALVES – PRÓXIMA**

Presence in more than 190 Countries, supporting all industries

The Largest Electrical Engineering Company in the World

Industry

Divisions

- Drive Technologies
- Industry Automation
- Building Technologies
- Mobility (trains technologies)
- Lighting (Osram)
- Industry Solutions



Energy

Divisions

- Fossil Power Generation
- Renewable Energy
- Oil & Gas
- Energy Service
- Power Transmission
- Power Distribution



Healthcare

Divisions

- Imaging & IT
- Workflow & Solutions
- Diagnostics



Siemens Brazil

Wide presence with equipment production and engineering

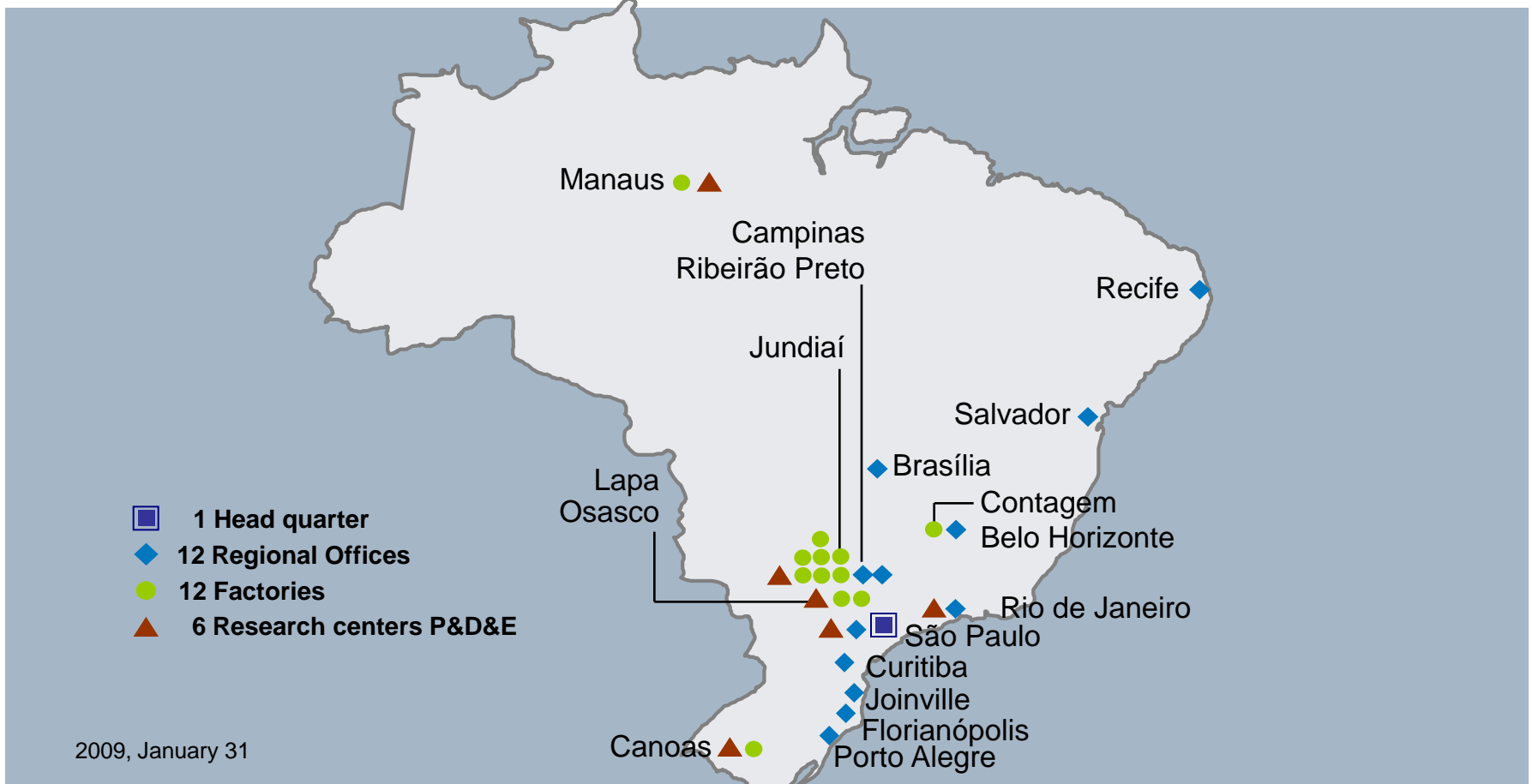
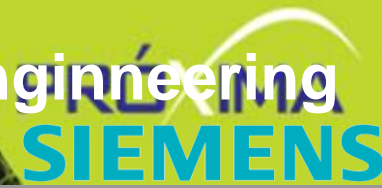

2009, January 31

Siemens One – focus on customer and segments

SIEMENS



- More than 2000 Account Managers supporting our biggest customers in the world
- Providing from one source sustainable and specific solutions to our customers

Ethanol Production Brazilian Market

According Archer Consulting estimations, agricultural risks studies company, the downsizing in the supply of ethanol could be even higher, reaching a growing deficit .

" The domestic demand for ethanol should be around 25 billion liters, not counting the other exports that require 3.3 billion, representing a deficit of 2.6 billion liters, estimated Arnaldo Correa, Archer risk manager.

According to Archer, the numbers still indicate that the sector will need to expand sugar 10.07% per annum until the harvest of 2012/2013, to meet the demands of domestic and foreign sugar and ethanol. "So it will take new investments in the sector that, by some estimates, should be about \$ 21 billion for the same period, until 2012/2013," said Correa.

Automation, Process and Energy Totally Integrated Architecture for Sugar and Ethanol Production

SIEMENS

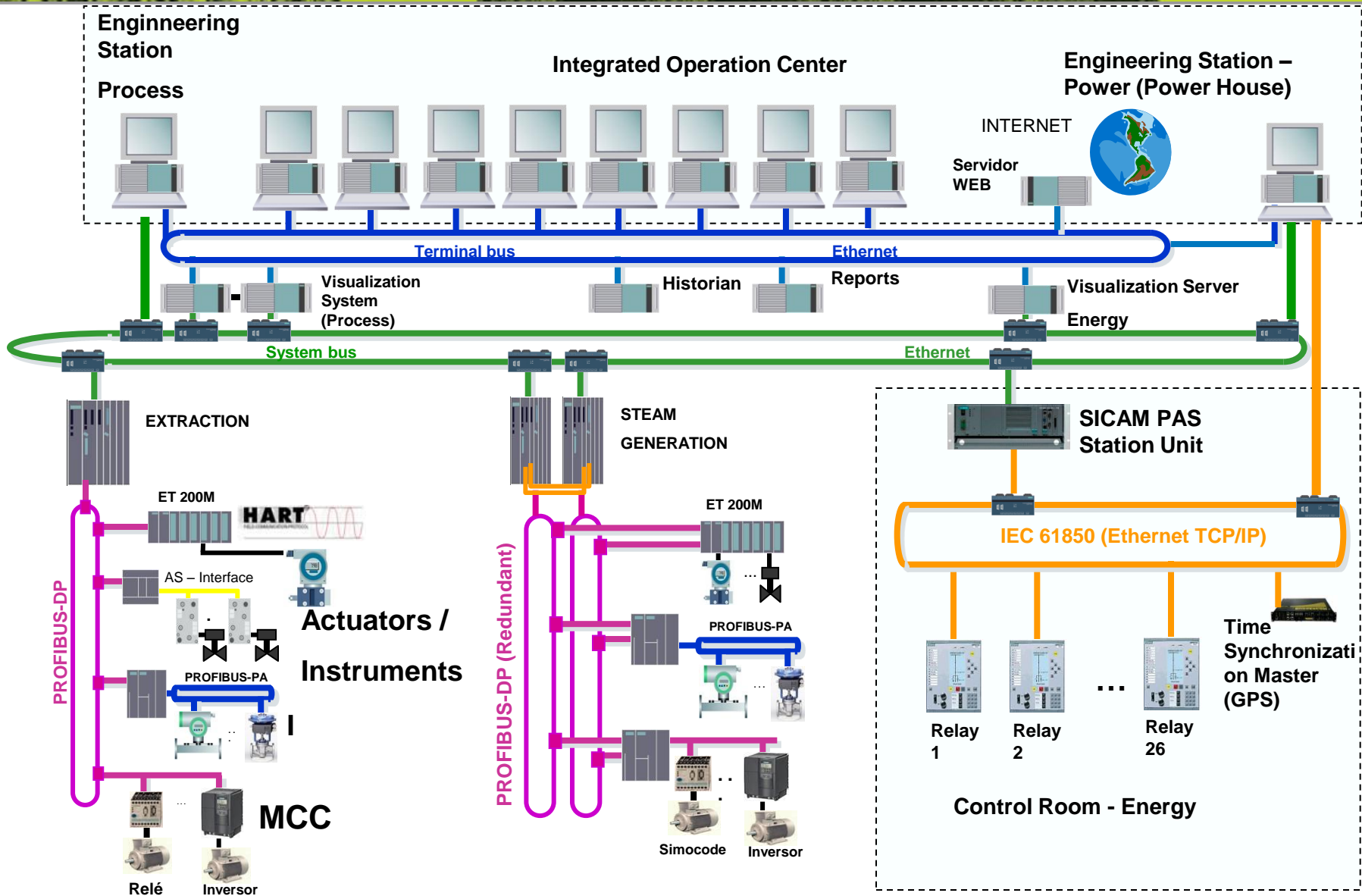

Online Monitoring of Production and Performance Analysis Monitoring

SIEMENS

STEAM GENERATION

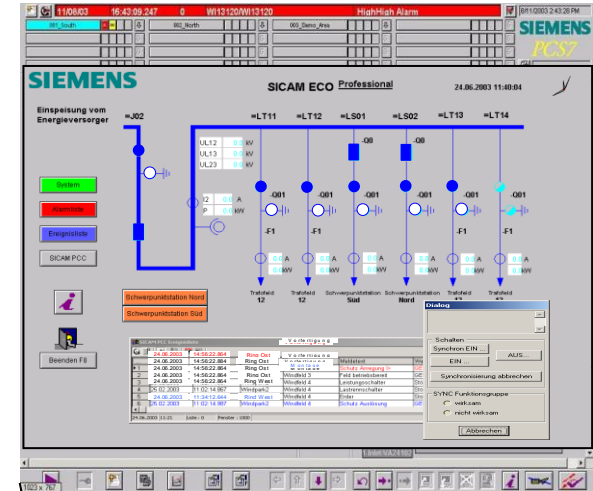

POWER HOUSE

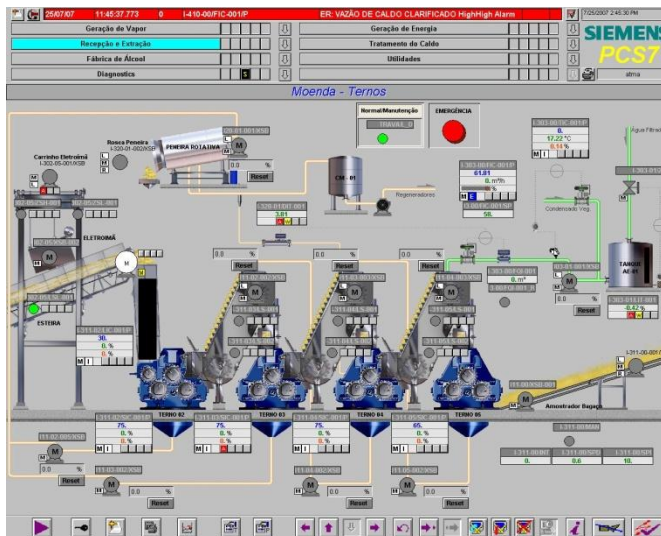
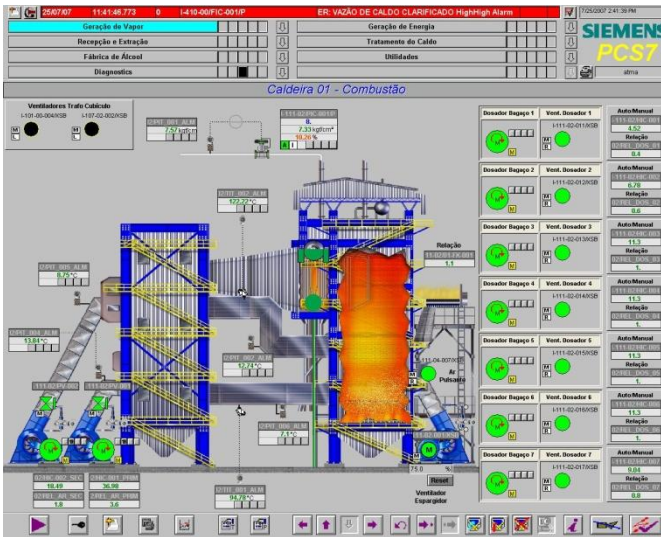

EXTRACTION

The top of the slide features a horizontal banner. On the left, there is a photograph of an industrial facility with tall distillation columns and piping. On the right, there is a photograph of a lush green sugarcane field. The banner has a light green background. The word 'Benefits' is written in white, bold, sans-serif font over the industrial image. The 'PRÓXIMA SIEMENS' logo is in the top right corner, with 'PRÓXIMA' in blue and 'SIEMENS' in a larger, bold blue font, with a white arc above the 'X' in 'PRÓXIMA'.

Benefits

- Increase in labor productivity, maintaining the quality of production, operational continuity.
- Asset Management.
- Centralization of operations of the factory.
- Replacing the man in dangerous activities.
- More effective participation of the Brazilian industry in the international market.
- Security and Reliability in Critical Systems
- Management Information Automation, Real Time
- Identification and Fault Management in Production Systems
- Engineering centralized and uniform for all components of the control system and field devices (instrumentation, valves, motors, etc.)
- Energy Automation
- A global view of process data in the existing controllers in a single Engineering Station

The top banner of the slide is split into two images. The left side shows a complex industrial structure with pipes and tanks, likely a refinery or chemical plant. The right side shows a lush green cornfield. The word 'Benefits' is written in white, bold, sans-serif font over the industrial image.

Benefits

The logo for 'PRÓXIMA SIEMENS' is located in the top right corner. 'PRÓXIMA' is in a dark blue, sans-serif font, and 'SIEMENS' is in a lighter blue, sans-serif font. A white curved line arches over the 'X' in 'PRÓXIMA' and the 'I' in 'SIEMENS'.

PRÓXIMA
SIEMENS

- Recognition and rapid elimination of errors and failures
- Save time by downloading from network
- Automatic synchronization of data saves time
- Reduced time stops
- Increased availability
- High degree of flexibility
- Increased transparency makes the optimization
- Inclusion of new equipment during the harvest without the need to stop production

Situation of Automation Plants in Brazil

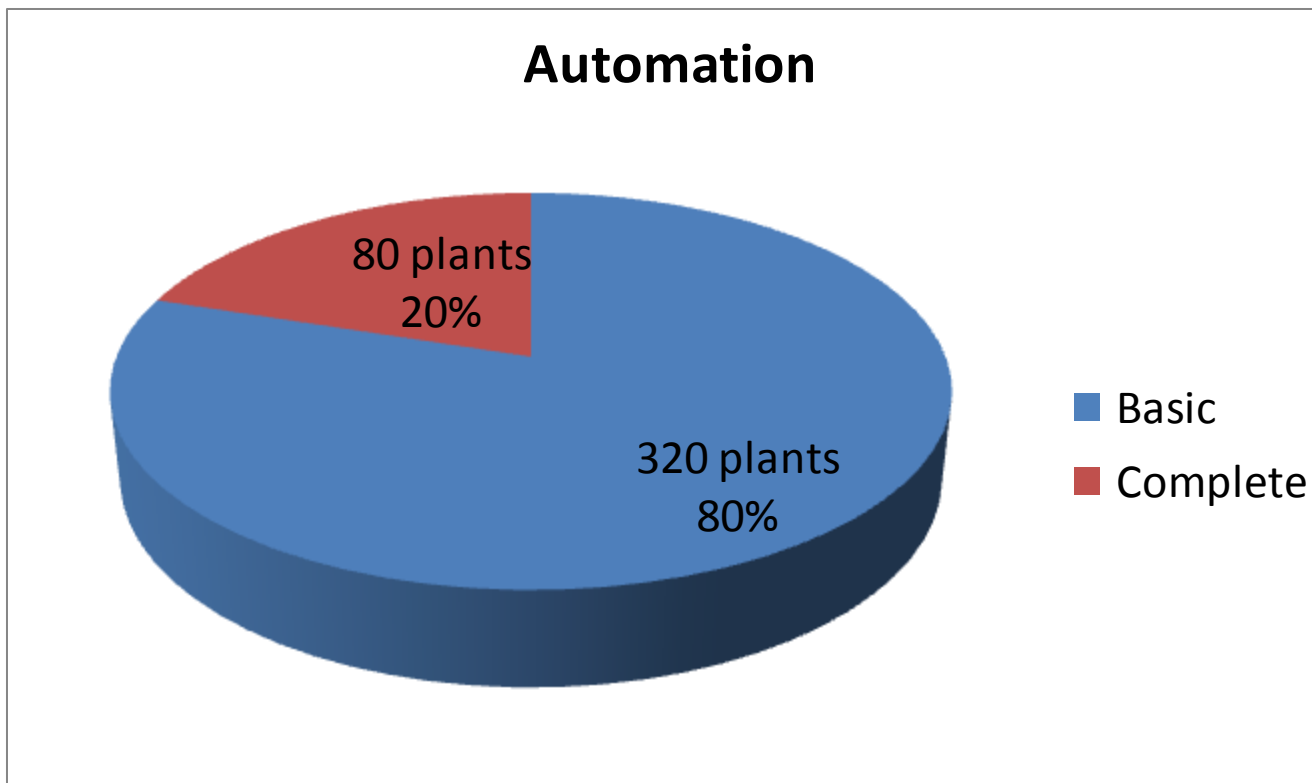



- Leaders in agribusiness management systems in Brazil
- 22 years of experience in the agribusiness sector
- + 190 customers
- 7,200 users
- Handling more than 250 million tons of sugar cane/year (45% of the Brazilian production)
- Customers in 4 countries (Brasil, Colombia, México and Peru)
- A TOTVS Company



9th world largest ERP software company

Business and technologies do not cover parallel track bars, but they have a “feedback” relation.

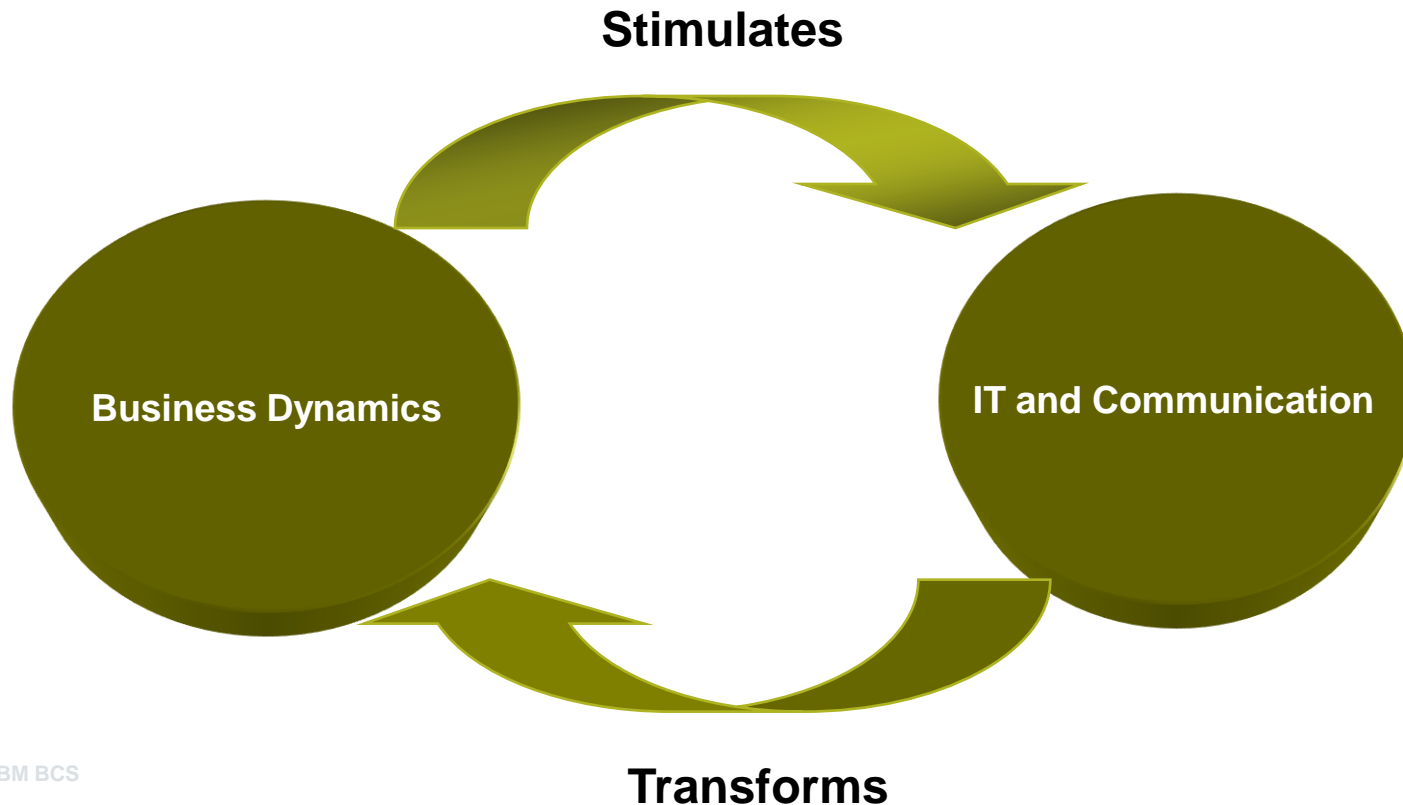

SOFTWARE IN THE ETHANOL BUSINESS PRODUCTION

ERP Software (SAP, ORACLE, TOTVS)

Business Software (PIMS-CS, PIMS-PI, PIMS-MI, UNILAB)

Intelligent Business Management (SIMATIC IT/PROXIMA)



PRÓXIMA
SIEMENS

ERP Software

ERP (*Enterprise Resource Planning*)

ERP - Solution that integrates all data and processes of the organization in a single system

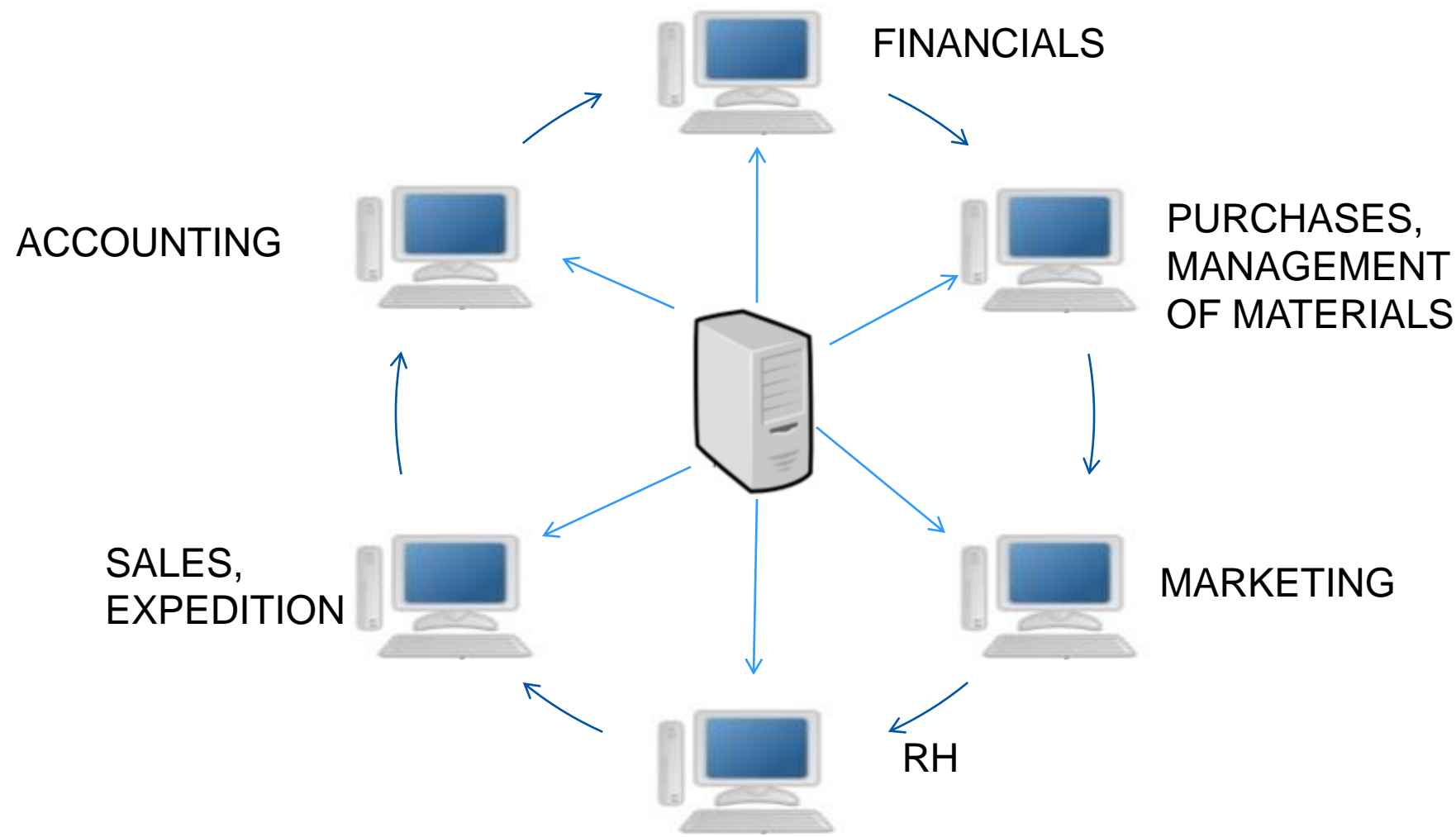

Advantages

- Eliminate the use of manual interfaces
- Costs Reduction
- Optimize the information flow
- Improve the quality of the organization information (efficiency)
- Optimize the decision process
- Eliminates redundancy of activities
- Reduce the time to market
- Reduce the *lead-time*
- Information security
- Integration between modules



PRÓXIMA
SIEMENS

Business Software

Agricultural Modules



PURCHASE



PLANTATION



TREATMENTS



HARVEST



DELIVERY



INDUSTRY

PLATIV – Planning of Activities and Resources

AGRONO – Agronomic Control

AUTOMOTIVE MAINTENANCE

PROCOL – Crop planning

CCT

SIG - Geographic Information

ATIREC – Activities and Resources Control

PGSERV – Payment of Third Party Services

PGFORN - Payment of Suppliers and Partners

CUSTAG – Operational Budget and Costs

BIA – Agricultural B.I.

Industrial Modules

PRÓXIMA



RECMAP - Reception and Analysis

Budget of the Quality control

Quality control of the Productive Process

Supplies of sugar and alcohol

**Losses Balance, Mass Balance,
EFFICIENCIES AND YELD**

Certification of Product Expedition

SPC

Management of Plans and Goals

Inputs

Management of the Industrial Laboratory (glasses, reagents, calibrations)

**Management and Control of the Industrial Maintenance
(preventive, emergencies and corrective)**

Planning and Control of the Lubrication

Planning and Control of the Period between harvests

CUSTAG – Operational budget and Costs

BIA Industrial B.I.

Customers

PRÓXIMA
SIEMENS



ingenio maria luisa s.a.



adecoagro

Strategy

**PRÓXIMA
SIEMENS**

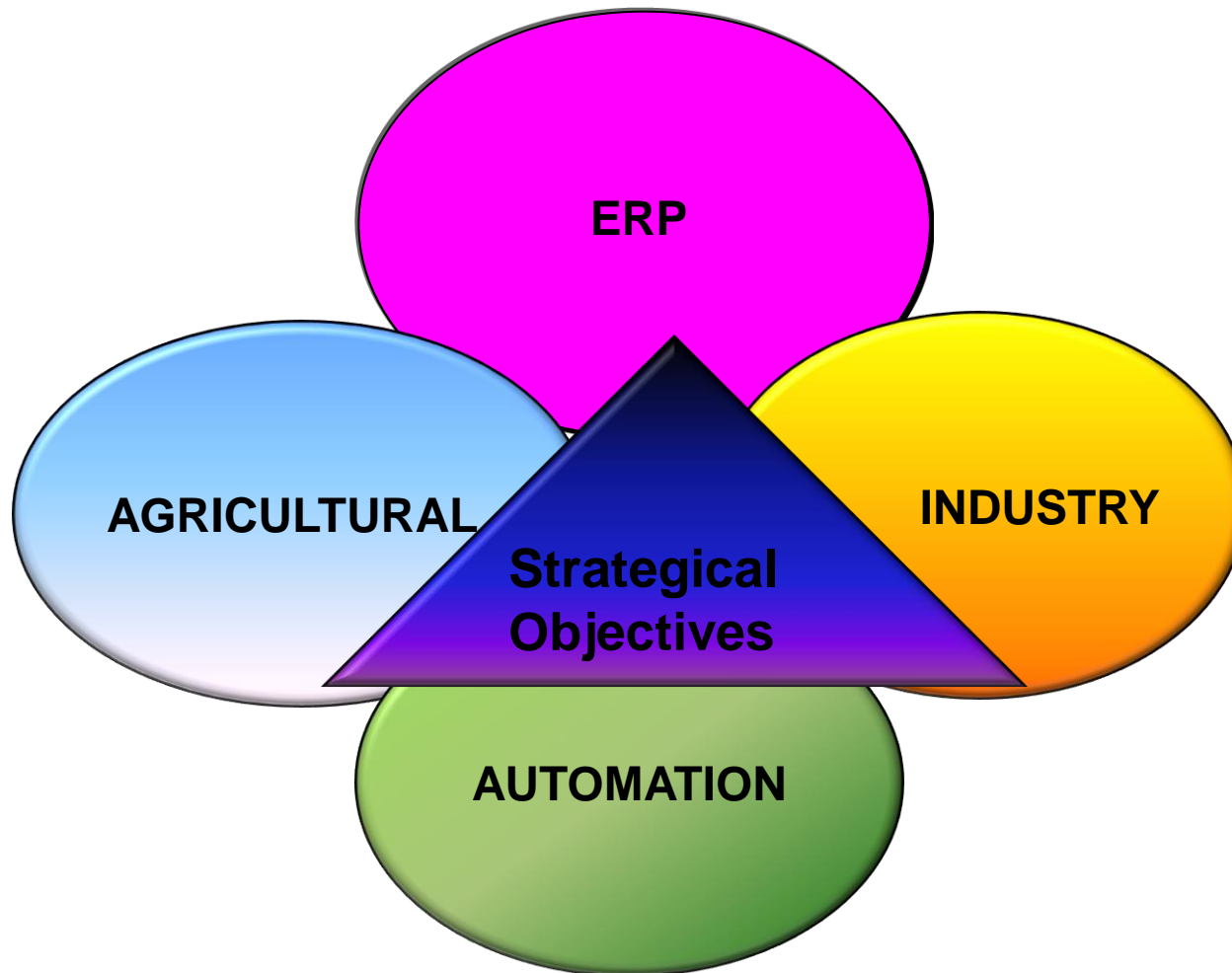



PRÓXIMA
SIEMENS

Intelligent Business Management Software

Integrated Vision

Management

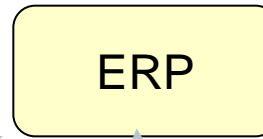

Systems core business

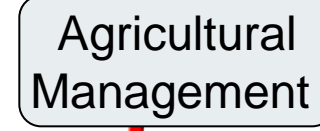
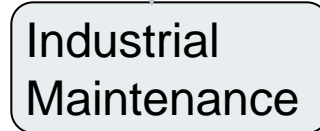
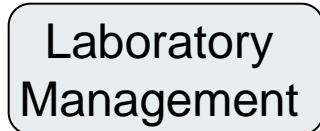

MES - SIMATIC IT

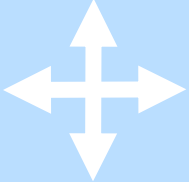

Vertical and Horizontal Integration

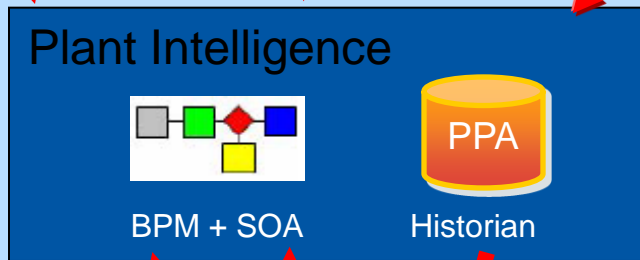

Automation

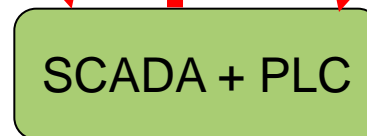

INTELLIGENT BUSINESS MANAGEMENT ORIENTED

Intelligent Business Management

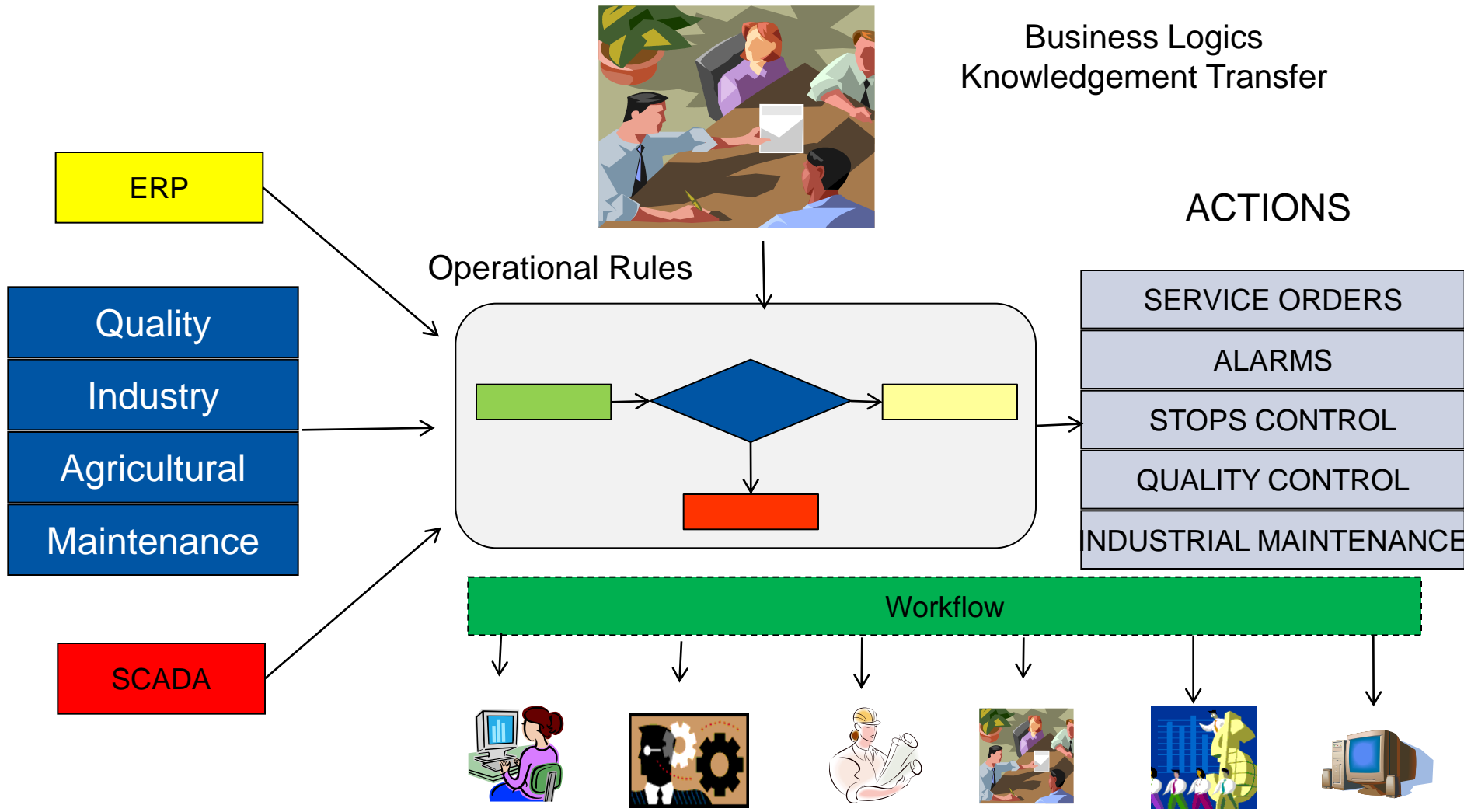

Real Time KPI Monitoring- Mills (Extraction)

PRÓXIMA SIMATIC IT

Controles Gerenciais | Produção e Estoque | Moenda | Tratamento de Caldo | Fermentação | Destilação | Fabricação Açúcar | Energia

Entrada da Cana

	Turno A	Turno B	Turno C	Dia	Safra	
Fibra da Cana:	12	11,98	11,70	11,90	11,86	32,49
Poi da Cana:	12	11,98	12,65	11,67	12,10	30,41
ART:	20	17,95	16,82	18,61	17,79	36,76
AR:	2	2,39	2,13	1,59	2,03	29,40
Perm. no Campo:	11	0,83	0,83	0,83	2,48	48,76
Cana Moída:	457	1813,10	1780,99	1806,51	5400,60	19187,41

Controle

	Turno A	Turno B	Turno C	Dia	Safra	
Poi do Bagaço:	1	1,89	1,88	2,14	1,97	24,16
Fibra do Bagaço:	49	48,01	48,64	49,53	48,73	50,30
Umidade do Bag:	20	22,27	28,14	30,07	26,83	38,86
Ton. ART/h efet.:	0,00	0,00	-1,00	0,00	-1,00	-4,83
Ton. Fibra/h efet.:	0,00	0,00	-1,00	0,00	-1,00	-4,83
Extração:	89	86,74	83,83	86,67	85,74	85,75

Oclação: 1,58, 18,01, 27,02, 45,04, 45,04

C.Donely: 9,01

EMBEBIÇÃO

Direta: 1456,42

Indireta: 1456,42

Controle de paradas

H. Inicio: 26/8/2009 16:8:44

H. Fim: 26/8/2009 16:9:11

Motivo:

Tempo: 150,07

	Turno A	Turno B	Turno C	Dia	Sem	Mes	Safra
Disponibilidade(%h)	352,97	357,15	352,81	1062,93	0,00	0,00	1062,93
Aproveit. Moagem Tot%T	352,13	348,18	350,23	1050,54	0,00	0,00	1050,54

Controle Rotação de Moenda

setpoint: 0,00

	Turno A	Turno B	Turno C	Dia	Sem	Mes	Safra
	12290,06	12117,02	12620,82	37027,90	0,00	0,00	37027,90

Time: 30/08/2009 18:00:00 | Value: 82,08 | 2 Item(s)

Agricultural

Agricultural

Industry

Industry

Automation

Automation

Real Time KPI Monitoring- Broth Treatment

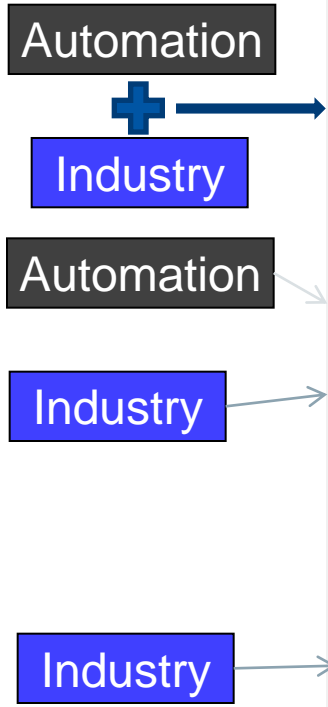

Controles Gerenciais
Produção e Estoque
Moenda
Tratamento de Caldo
Fermentação
Destilação
Fabricação Açúcar
Energia

Álcool

Coeficiente Global de Troca Térmica

Aq3415: 86,40 85,43 85,43 86,11 86,11

Decantador para Álcool

	Turno A	Turno B	Turno C	Dia	Safra	
T. Ent. Decant:	17	1097,70	1124,40	1124,40	1128,75	518,54
Vazão Caldo:	14	135,99	191,02	191,02	200,00	153,26
Vazão Lodo:	14	1097,70	1124,40	1124,40	1128,75	516,40
Turbidez:	14	6,88	8,97	8,97	8,38	37,39
Brix:	14	17,44	17,32	17,32	17,67	30,77
Ph:	14	3,39	3,44	3,44	3,61	31,42
Pol:	14	15,36	15,26	15,26	15,56	33,89
Pureza:	58	59,61	57,57	57,57	58,90	54,46

Açúcar

Coeficiente Global de Troca Térmica

Aq3403: _____
Aq3404: _____
Aq3405: _____

Decantador para Açúcar

	Turno A	Turno B	Turno C	Dia	Safra	
T. Ent. Decant:	243,820	0,00	0,00	0,00	0,00	2,14
Vazão Caldo:	243,820	0,00	0,00	0,00	0,00	2,14
Vazão Lodo:	1268,68	0,00	0,00	0,00	0,00	0,00
Turbidez:	8	6,88	8,11	5,74	6,94	6,94
Brix:	19	17,53	18,54	19,26	18,37	32,58
Ph:	3	4,11	3,81	3,38	3,80	23,77
Pol:	16	16,06	16,09	15,01	15,78	31,95
Pureza:	51	59,69	53,99	55,37	56,43	56,43

Eficiência do Tratamento do Caldo

Item Name	Property	Value
EFIC_TRATAMENTO_...		87,75

Time: 27/08/2009 14:58:46 Value: 87,75 1 Item(s)

	Turno A	Turno B	Turno C	Dia	Safra	
	88	84,24	84,49	86,22	84,98	75,84

Filtros

	Turno A	Turno B	Turno C	Dia	Safra	
Vazão do Caldo Filtrado:	243,820	66,03	95,07	123,80	100,17	108,10
Pol da Torta:	0	1,29	0,54	0,40	0,74	11,48

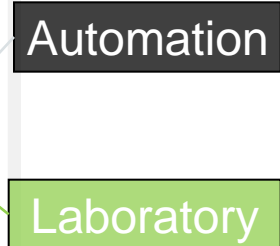

Real Time KPI Monitoring- Sugar Production and Stocks



Controles Gerenciais
Produção e Estoque
Moenda
Tratamento de Caldo
Fermentação
Destilação
Fabricação Açúcar
Energia

Fabricação Açúcar

	Turno A	Turno B	Turno C	Dia	Safra
Tmp. Cozimento:	0	4,365	5,06	3,4125	4,27916l 26,082
Brix da Massa A:	87	4,365	5,06	3,4125	4,27916l 26,082
Brix da Massa B:	89	4,365	5,06	3,4125	4,27916l 26,082
Brix Magna:	4,365	5,06	3,4125	4,27916l	26,082

Carregamento do Açúcar

	Turno A	Turno B	Turno C	Dia	Safra
	0	0	0	0	0

Paradas centrífuga 1

H. Início: 26/8/2009 16:8:44 Tempo: 0,27

H. Fim: 26/8/2009 16:9:11

Motivo:

Turno A	Turno B	Turno C	Dia	Safra

Paradas centrífuga 2

H. Início: 26/8/2009 16:8:44 Tempo: 0,27

H. Fim: 26/8/2009 16:9:11

Motivo:

Turno A	Turno B	Turno C	Dia	Safra

Produção e Estoque do Açúcar

	Turno A	Turno B	Turno C	Dia	Safra
Produção:	946642,1	2703800	3554313	7204756	1251103
Estoque Granel:					
Estoque BigBag:	0				

Mel

Nível:	1269,17l	Turno A	Turno B	Turno C	Dia	Safra
Brix:	88	84,63	85,07	84,485	84,7283l	67,6712
Pureza:	81	84,8275	84,475	84,78	84,6941l	65,966

Industry

Automation

ERP

Industry

ERP

Industry

Copyright © 2004 - 2009 Próxima Software e Serviço. Todos os direitos reservados.

Difficulties

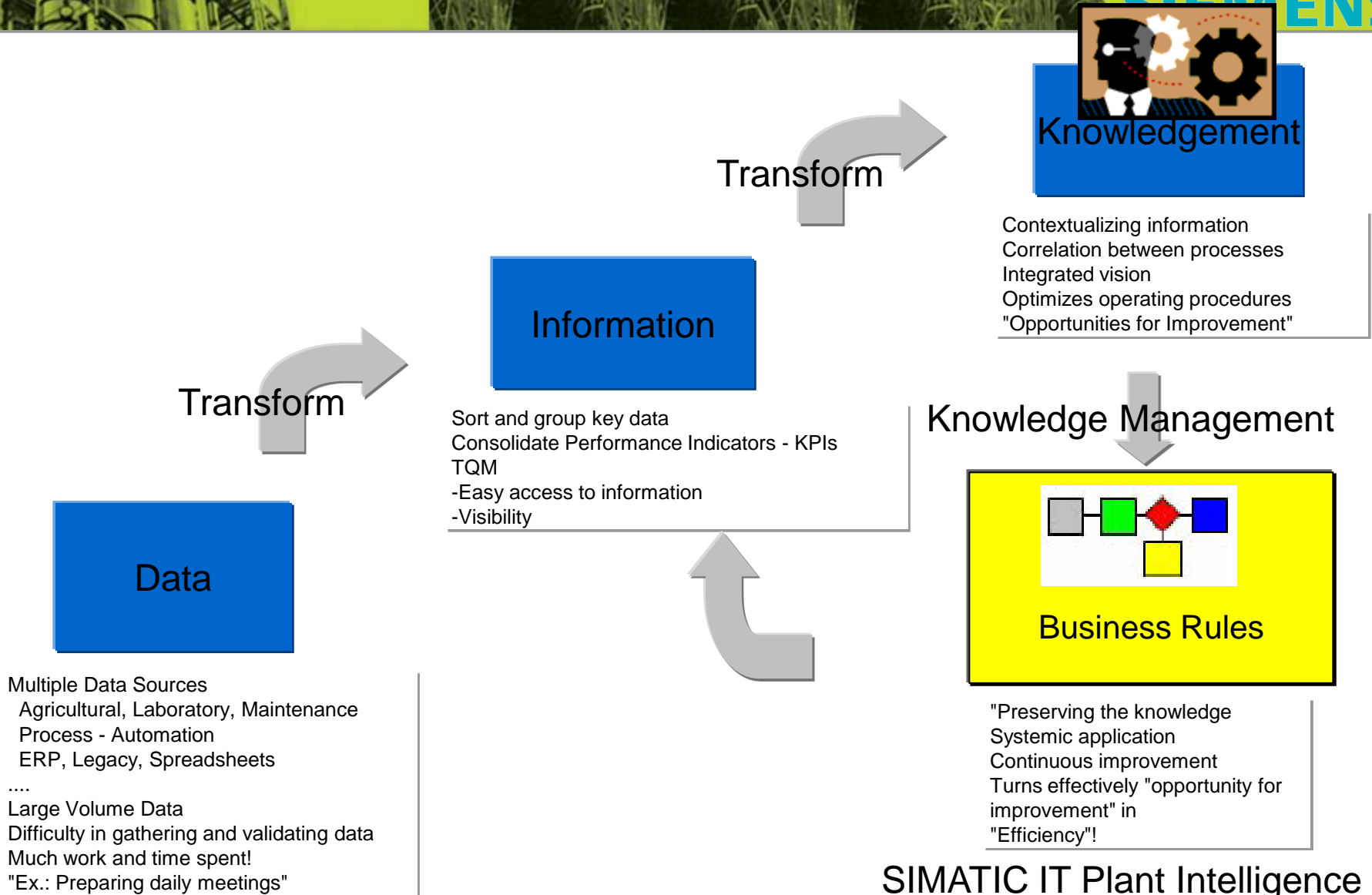

The top banner of the slide features a split background. On the left, there is a photograph of an industrial facility with tall distillation columns and piping. On the right, there is a photograph of a lush green cornfield. The text 'Direct and indirect Benefits' is overlaid in white on the left side of this banner.

Direct and indirect Benefits

- Production costs control in each stage of the productive process
- Reach of the best performance index
- Security in the generated information
- Reduction costs verification time
- Reduction losses risks
- Track and Trace
- Improvement of Productivity
- Decision taking security

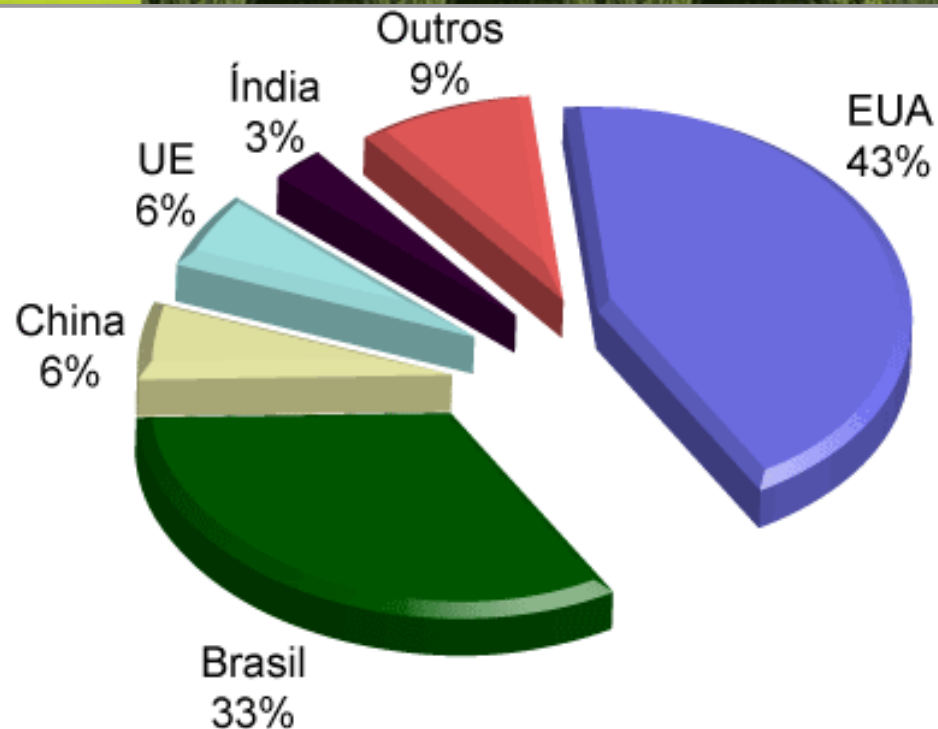

Brazil is the second largest ethanol producer in the world,
Largest exporter
Second largest consumer.

The country produced about 22.4 billion liters of alcohol in the season 2007 / 8, up 28% of national production of 2006/2007.

Of this total, about 16% was exported

(Source: DATAGRO).

New Markets for Ethanol



Plants in Brazil

SOFTWARES	OWN	MARKET	ADVANTAGES
ERP	15-25%	75 – 85%	MANAGEMENT CONTROL
BUSINESS	30-40%	60-70%	MANAGEMENT AND CONTROL OF BUSINESS ACTIVITIES
INTELLIGENT BUSINESS MANAGEMENT (ERP+BUSINESS +AUTOMATION)	0%	3%	MAXIMIZING THE DEVELOPMENT OF PRODUCTIVE CAPACITY DECISION MAKING IN REAL TIME BEST PERFORMANCE KPIs

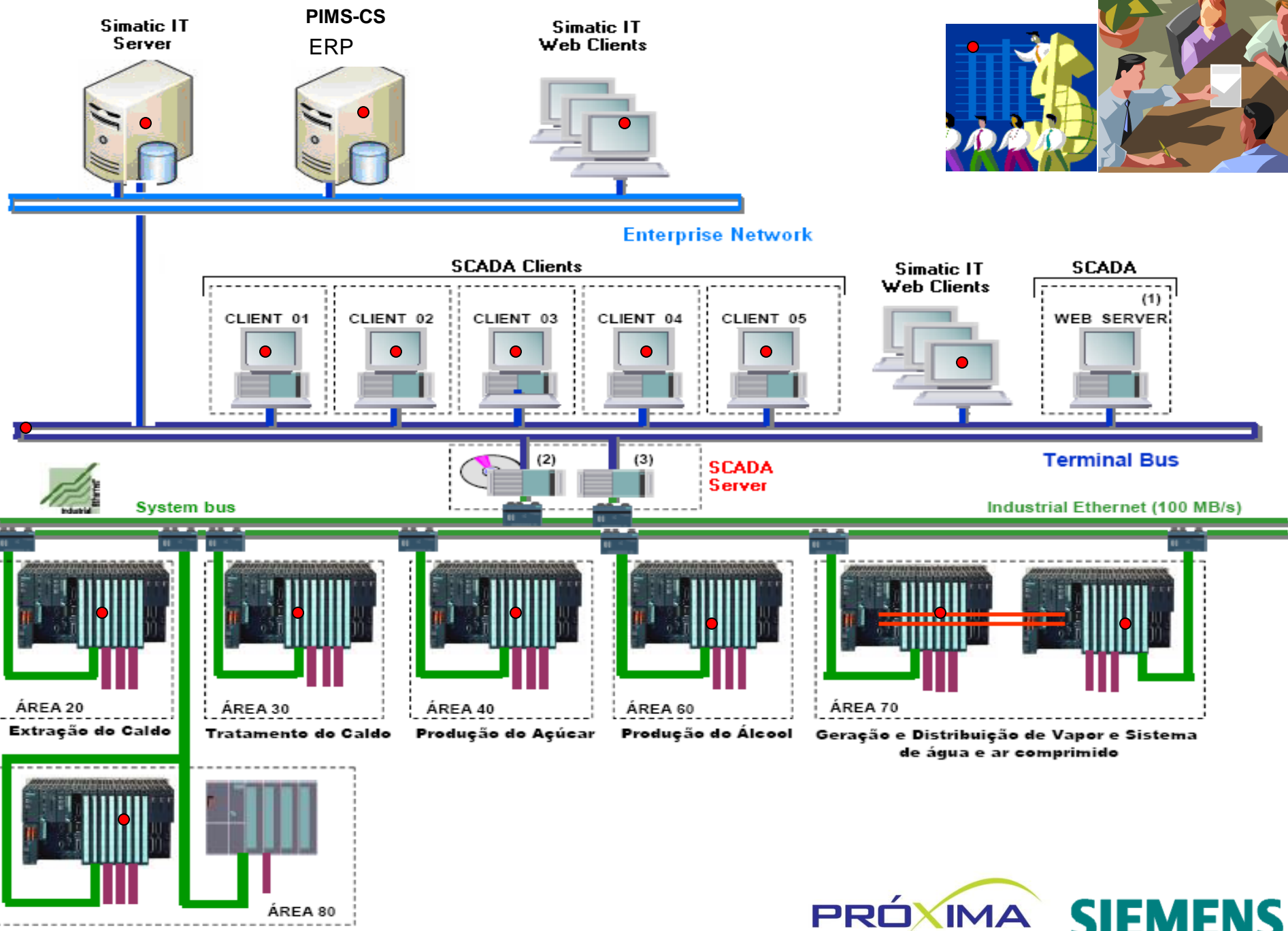



Thank You!

CHRISTIAN ROBSON MARCATTO – SIEMENS
Sugar and Ethanol Specialist

LOURDES ANDREO GONÇALVES – PRÓXIMA
Project Manager